

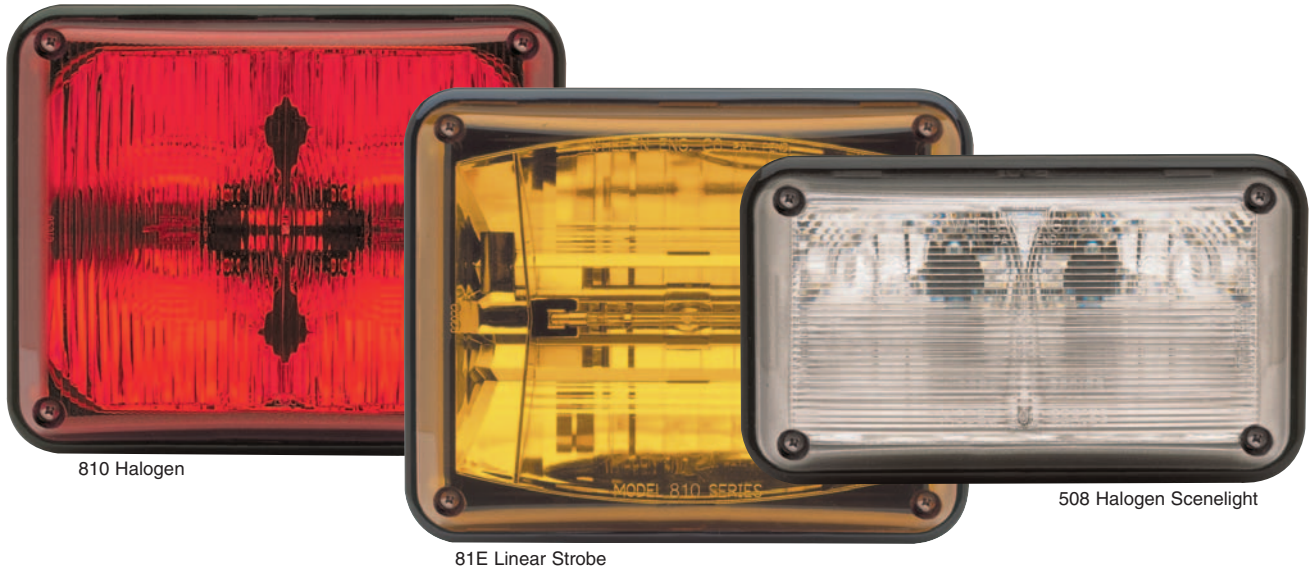

Officially Licensed
Warning Lights Of
NASCAR®

508 & 810 Series

SURFACE MOUNT STROBE AND HALOGEN LIGHTHEADS



810 Halogen

81E Linear Strobe

508 Halogen Scenelight

508 & 810 SERIES - SURFACE MOUNT LIGHTHEADS

Surface mounted warning lights keep moisture from building up on the surface of your vehicle and simplify installation and maintenance.

Surface mount lightheads require only a 3/8" wire access hole. Lighthead positioning is flexible because without large cutouts, the unit can be mounted almost anywhere on the vehicle without worrying about structural members or frames.

FEATURES

- Eliminates large cut-outs on your vehicle.
- Only four mounting screws, and an access hole for cable are needed making installation and maintenance easier.
- 8-32° scenelight model featuring snap-in relampable 27 watt bulbs.
- Lens is easily removed for easy access and service in the field.
- Strobe models include 15' of 3-C shielded cable with AMP Mate-N-Lok® connectors; halogen include 6" pigtails.
- A full line of complimentary design lightheads provide primary and secondary lighting such as scene-lighting or brake/tail/turn signals.
- Split lens models are available.
- Optional chrome plated flange.

MODELS

508 Models

- 58EC20*U: Linear strobe
- 58EC20#U: Linear strobe, split lens
- 58CAA*R: Dual 27 watt halogen
- 58CAA#R: Dual 27 watt halogen, split lens
- 58CAAZR: 8-32° halogen scenelight
- 508TRIM: Chrome plated flange

810 Models

- 81EC20*U: Strobe
- 81EC20#U: Strobe, split lens
- 810CAA*R: Dual halogen
- 810CAA#R: Dual halogen, split lens
- 810CA0ZR: 8 - 32° Scenelight
- 810TRIM: Chrome plated flange

*Replace symbol in model number with letter indicating lens color or LED color desired: A= Amber, B = Blue, C = Clear/White, R = Red, G = Green.

#Replace symbol in model number with letter indicating split lens or LED color desired: D = Red/Clear, E = Blue/Clear, F = Amber/Clear, H = Green/Clear, J = Red/Blue, K = Red/Amber, L = Red/Green, M = Blue/Amber.



Available in red, amber, green, blue, and clear

Form# SURF0805



Designed &
Manufactured
in the U.S.A.

WHELEN®
Engineers for the Emergency Warning Industry

508 Series Halogen & 508E Series Linear Strobe

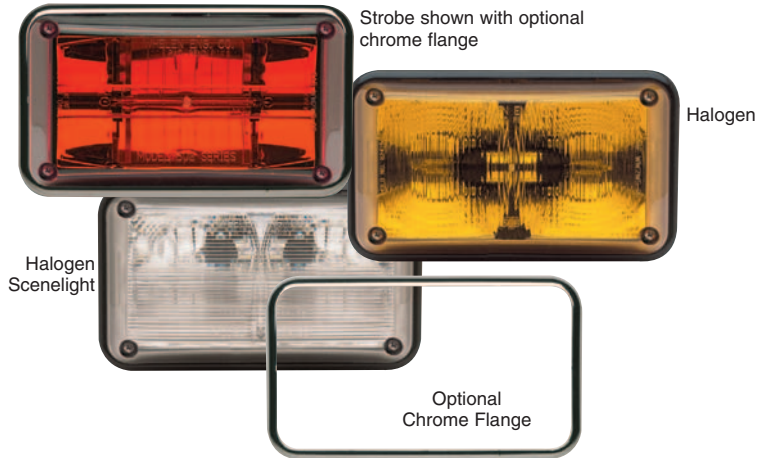
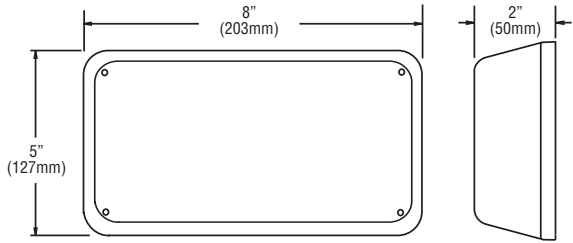

810 Series Halogen & 81E Series Linear Strobe

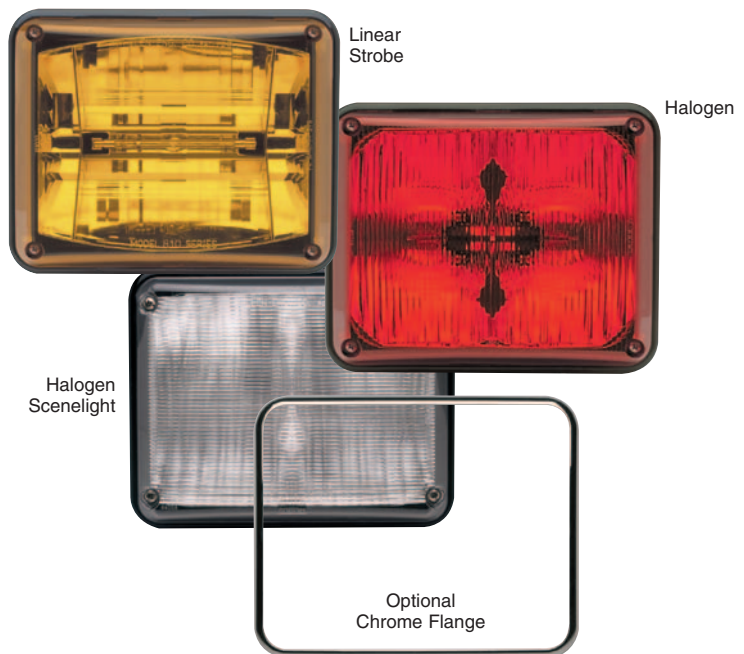
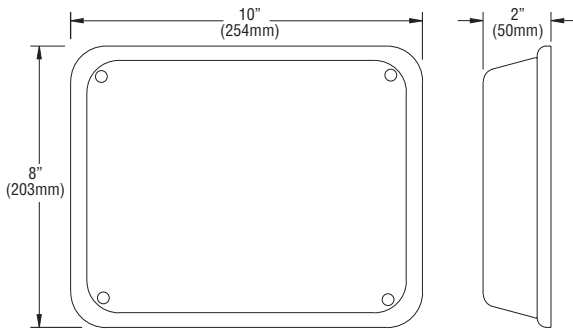

WHELEN[®]
ENGINEERING COMPANY, INC.

Route 145, Winthrop Road
Chester, Connecticut 06412-0684
(860) 526-9504 • Fax: (860) 526-4078
www.whelen.com



Whelen Engineering reserves the right to upgrade and improve products without notice.

© 2005 Whelen Engineering Company, Inc.
Form No. 10118B-0805
NASCAR[®] is a registered trademark of the National Association for Stock Car Auto Racing, Inc.