

Model HELS™

SIDE MOUNT STROBE LIGHTHEAD

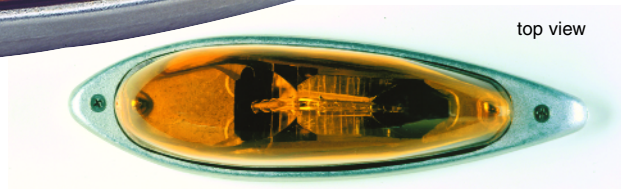

top view



HELs side mount strobe lightheads provide warning light protection on heavy construction equipment from below the roof line and avoids breakage from overhead hazards.

Effective and practical for D.O.T. and Work Zone Safety construction applications, HELs lightheads are recommended for use in pairs on the sides of road graders, bucket loaders and backhoes to achieve 360° coverage.

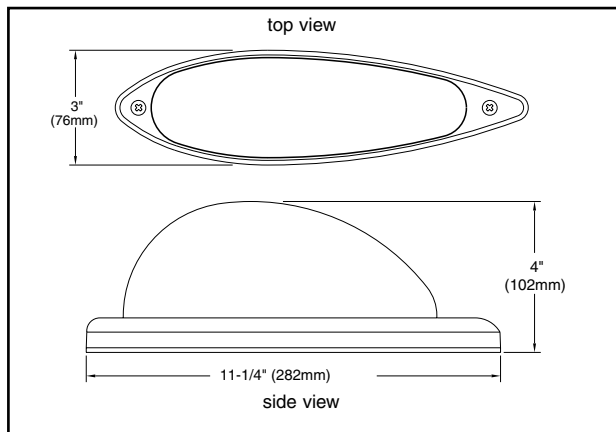

FEATURES

- Aerodynamic "tear drop" shape resists snagging on tree branches and other obstructions.
- Self cleaning smooth outer lens surface.
- Optically corrected lens is available in all five safety colors.
- Wide angle, 180° horizontal coverage with unique "V" shaped strobe tube and reflector.
- Rugged design uses cast aluminum mounting plate and bezel.

- Compact size: 4" (102mm) H x 11-1/4" (282mm) L x 3" (76mm) W.
- Rubber gaskets provide weatherproof seals between lens to mounting plate and lighthead to mounting surface.
- Surface mount lighthead attaches with two mounting fasteners and requires only one cable access hole for installation.
- Supplied with 15' cable and AMP Mate-N-Lok® connector.
- For use with Whelen Strobe Power Supplies, sold separately.

MODEL HELS*

Side mount strobe lighthead with 15' cable and connector.

Replace * in model number with lens color desired:
A=Amber; **B**=Blue; **R**=Red; **G**=Green; **C**=Clear)



Available in
all 5 safety colors

Form# HEL0203

© 2003 Whelen Engineering Co., Inc. Printed in U.S.A.
 Whelen Engineering reserves the right to upgrade and improve products without notice.
 Code: 10231C - 0203

WHELEN®

ENGINEERING COMPANY, INC.

Route 145, Chester, CT 06412-0684
 (860) 526-9504 • Fax: (860) 526-4078
 www.whelen.com

Engineers for the Emergency Warning Industry

MODEL HELS - D.O.T. SIDE MOUNTED STROBE LIGHT